

ITEM NO.	DESCRIPTION	QTY.
1	3/0, 14 INDEX DIE SET	1

CATALOG NUMBER	DESCRIPTION
HW27RT	3/0, 14 INDEX DIE SET

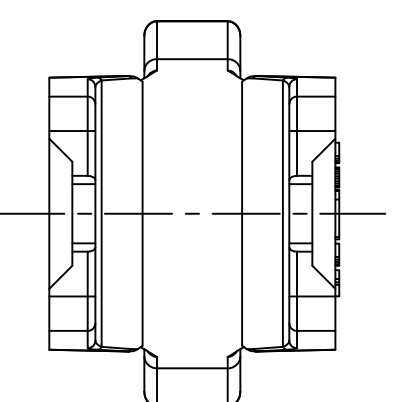
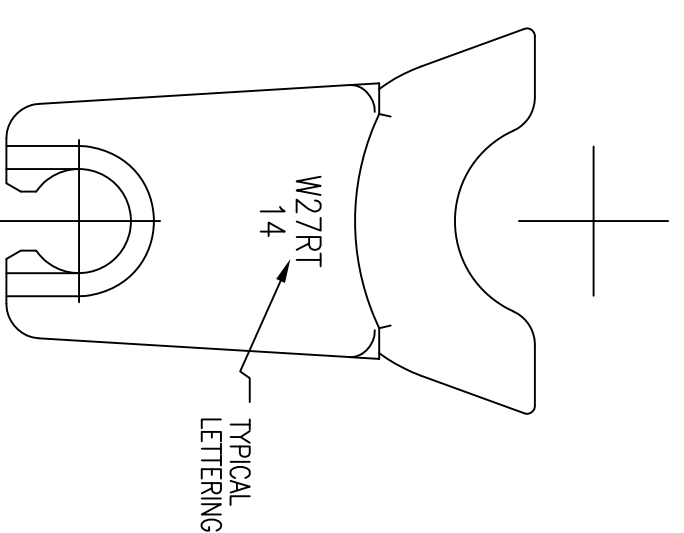
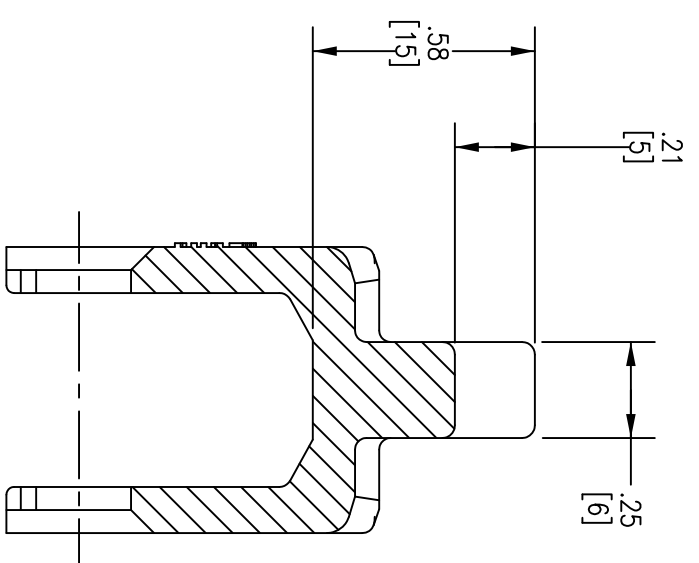
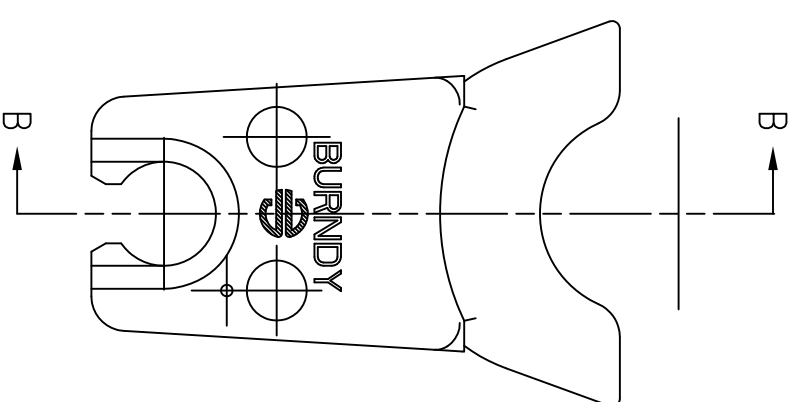
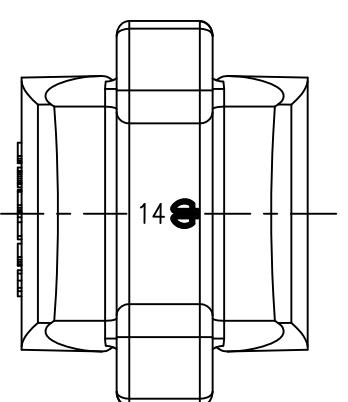

- TECHNICAL NOTES:
1. MATERIAL: STAINLESS STEEL.
  2. DIE SET CATALOG TO CONTAIN TWO (2) DIE HALVES.
  3. DIMENSIONS IN BRACKETS [ ] ARE IN MILLIMETERS, ROUNDED OFF TO THE NEAREST MILLIMETER, UNLESS OTHERWISE SPECIFIED, AND ARE FOR REFERENCE ONLY.
  4. FITS HPAT600L AND HMD7 COMPRESSION TOOLS.
  5. SPECIFICATIONS SUBJECT TO CHANGE WITHOUT NOTICE.

REV.	ECN	DATE	DESCRIPTION	CHG BY	APPD BY
1	17987	8/13/12	INITIAL RELEASE	CG	

Created on AUTOCAD

DIMENSIONING AND TOLERANCE PER ANSI Y14.5M-1982 UNLESS OTHERWISE SPECIFIED, DIMENSIONS ARE IN INCHES (MM).  
TOLERANCES  
.XXX = ±.01 (.25)  
.XXX = ±.005 (.127)  
.XXXX = ±.0025 (.0635)  
ANGLE TOL ±.1°

IN ACCEPTING OUR DRAWINGS, BLUEPRINTS, OR SUPPORTING DOCUMENTATION FOR QUOTATION OR OTHER PURPOSES, YOU AGREE NOT TO DISCLOSE TO OTHERS THE IDEAS, INFORMATION, OR DESIGNS SHOWN HEREIN, AND THAT YOU WILL MAKE NO USE OF SAME WITHOUT PERMISSION

PROJECT REFERENCE: 2011-041

MATERIAL: SEE NOTES

DRAWN BY: C. GRIBBLE 8/13/12

CHECKED BY:

APPROVED BY:

Hubbell  
**Hubbell Premise Wiring**  
HUBBELL INCORPORATED (Delaware)  
23 CLARA DRIVE, SUITE 103 MYSTIC, CT 06355

TITLE: DIE SET, 3/0, 14 INDEX W DIE SET FAMILY

SIZE: C DRAWING NO. HWS14125C REV. 1

SCALE: 1/1 SHEET 1 OF 1